



Easy Radiant "Works"

12288 Side Road 22, Wainfleet, Ontario, Canada L0S1V0
 Phone 905 899 3473 Fax 905 899 2262
 www.erwcan.com email erw@vaxxine.com



2-STAGE HIGH INTENSITY GAS INFRARED HEATERS

INSTALLATION INSTRUCTIONS

APPLIES TO:

- Installation Operation Maintenance

! WARNING !

Improper installation, adjustment, alteration, service or maintenance can cause property damage, injury or death. Read the installation, operating, and service/maintenance instructions thoroughly before installing or servicing this equipment.

! WARNING !

Gas-fired appliances are not designed for use in hazardous atmospheres containing flammable vapors or combustible dust, or atmospheres containing chlorinated or halogenated hydrocarbons. See Hazard Intensity Levels, column 2.

FOR YOUR SAFETY

The use and storage of gasoline or other flammable vapors and liquids in the vicinity of this appliance is hazardous.

FOR YOUR SAFETY

If you smell gas:

1. Open windows.
2. Do not touch electrical switches.
3. Extinguish any open flame.
4. Immediately call your gas supplier.
5. If gas supplier cannot be reached, call fire department.

These heaters must NOT be used in the following applications:

- Enclosed swimming pool areas.
- Areas with contaminated atmospheres.
- Areas requiring explosion-proof equipment.
- Process heating applications.

HAZARD INTENSITY LEVELS

1. DANGER: Failure to comply will result in severe personal injury or death and property damage.
2. WARNING: Failure to comply could result in severe personal injury or death and/or property damage.
3. CAUTION: Failure to comply could result in minor personal injury and/or property damage.

FOR INDOOR INSTALLATION ONLY. NOT FOR RESIDENTIAL USE.

CONTENTS

Section No.	Page No.
1. General Information and Installation Codes.....	2
2. Unpacking.....	2
3. Installations other than Space Heating.....	3
4. Basic Dimensional Data.....	3
5. Clearance to Combustibles.....	3
6. Mounting Considerations.....	4
7. Ventilation Requirements.....	4
8. Gas Supply.....	4
9. Electrical Supply and Thermostatic Control.....	5
10. Suspending the Unit.....	6
11. Assembly.....	6
12. Ignition and Operation.....	7
13. Shut Down.....	8
14. Gas Pressure.....	8
15. Accessories.....	8
16. Maintenance and Service.....	8
17. Gas Conversion.....	9
18. Replacement Parts.....	9
19. Troubleshooting.....	10

ATTENTION!

Mount a copy of these instructions adjacent to the heater and retain a copy for future reference.

1. GENERAL INFORMATION AND INSTALLATION CODES

These infrared heaters are CSA International Designed Certified and manufactured in compliance with the harmonized standard ANSI Z83.19 / CSA 2.35-latest edition, approved by the American Standards Institute, Inc. and the Interprovincial Gas Advisory Council. These units are approved for indoor commercial and industrial installation only. Installation should be done by an authorized distributor or other qualified agency in accordance with these instructions and in compliance with all codes and requirements of authorities having jurisdiction.

IMPORTANT *

United States: These infrared heaters are the unvented type and are classified as Category I by the National Fuel Gas Code. The fresh air requirement of 4 CFM per 1,000 BTUH ($0.38\text{m}^3/\text{minute per kW}$) must be provided when operating the heaters. Refer to Section 7, Ventilation Requirements.

*** In Canada:** The fresh air requirement of 3 CFM per 1,000 BTUH ($0.29\text{m}^3/\text{minute per kW}$) for Natural Gas and 4 CFM per 1,000 BTUH ($0.38\text{m}^3/\text{minute per kW}$) for LP/propane gas must be provided when operating the heaters. Refer to Section 7, Ventilation Requirements.

Infrared heaters should not be installed in buildings with uninsulated metal roof decks. Uninsulated metal roof decks will cause condensation of water vapor (contained in the heater flue gas) on the inside of the building. Metal roof decks must be insulated using built-up insulation and roofing on the exterior or, inside insulation that is not permeable to water vapor. Interior insulation that is permeable to water vapor must be completely sealed with a vapor barrier.

INSTALLATION CODES

The installing contractor must be familiar with all the various requirements and is responsible for installing the heater in compliance with the applicable codes.

United States: Installations must be in accordance with the current National Fuel Gas Code ANSI Z223.1/NFPA 54 and all local codes. The National Fuel Gas Code is available from CSA International, 8501 East Pleasant Valley Road, Cleveland, Ohio 44131-5575. All electrical wiring must be in accordance with the current National Electric Code ANSI/NFPA No. 70.

Canada: Installations must be in accordance with the current Natural Gas and Propane Installation Code, CSA B149.1 and Installation Code for Gas Burning Applications and Equipment, B149.2. Canadian authorities having jurisdiction should be consulted, before installations are made, to verify local codes and installation procedures. All electrical wiring must be in accordance with the current Canadian Electrical Code, Part I and Part II CAN/CSA C22.1 and Electrical Features of Fuel-Burning Equipment, CAN/CSA 22.2 No. 3.

AIRCRAFT HANGARS

Heaters shall not be located in an area of an aircraft hangar where it may be subjected to physical damage by aircraft, cranes, moveable scaffolding, or other objects.

United States: The heaters must be installed in accordance with ANSI/NFPA 409-latest edition, Chapter 5. NFPA publications are available from the National Fire Protection Association, Batterymarch Park, Quincy, MA 02269. The standard specifies a clearance of 10 feet (3m) to the bottom of the heater from the highest surface of the wings or engine enclosures of the highest aircraft, which may be housed in the hangar.

Canada: Installations in an aircraft hangar must comply with the latest edition of CAN/CGA-B149.2, Section 4.21. An infrared heater installed in an aircraft hangar must be at least 3m (10 feet) above either the highest fuel storage compartment or the highest engine enclosure of the highest aircraft which may occupy the hangar.

In both the **United States** and **Canada**, a minimum clearance of 8 feet (2.5m) must be maintained from the floor to the heater in other sections, such as offices or shops, that communicate with the aircraft hangar.

REPAIR GARAGES

United States: Heaters installed in public garages must be in accordance with National Fire Protection Association (NFPA) 88B-latest edition, Section 3-2.3. Overhead heaters must be located not less than 8 feet (2.5m) above the floor and installed in accordance with the conditions of their approval. NFPA 88B-latest edition requires the following warning:

! WARNING !

Minimum clearance marked on the heater must be maintained from vehicles parked under the heater.

Canada: In a repair garage, the minimum clearance from the bottom of an infrared heater to the upper surface of the highest vehicle which may be housed therein shall be 50 percent greater than the certified clearance, and in no case less than 2.5m (8 feet).

PARKING STRUCTURES

This heater is suitable for use in parking structures when installed in accordance with requirements in NFPA 88A-latest edition.

HIGH ALTITUDE

Heaters are manufactured for use at the specific altitude range stated on the heater serial plate. Do not install heater if it is not rated for the correct altitude.

2. UNPACKING

This heater is completely assembled, 100% factory tested, inspected prior to shipment, and ready for installation.

Review the transportation company's bill of lading and/or freight bill. Observe and confirm the number of packages received agrees with the quantity indicated on the documents. If there is any disagreement or any part of the shipment is visibly damaged, note the nature and extent of it on the documents. If damage is discovered after delivery, leave the damaged material in the original shipping container(s) and immediately call the transportation company and request for an inspection to be made.

3. INSTALLATIONS OTHER THAN SPACE HEATING

Use for process heating applications VOIDS the warranty and CSA design certification.

WARRANTY VOID IF UNIT IS...

- Used in atmospheres containing flammable vapors or atmospheres containing chlorinated or halogenated hydrocarbons.
- Installed without proper clearance to combustible materials or in a location where the heater controls can be subjected to ambient temperatures above 150°F (66°C) or below -40°F (-40°C).
- Installed at angles not approved for the model.
- Installed for other than space heating applications.
- Altered. Units are completely factory assembled and tested.

4. BASIC DIMENSIONAL DATA

FIGURE 1 – LENGTHS, WIDTH AND HEIGHT

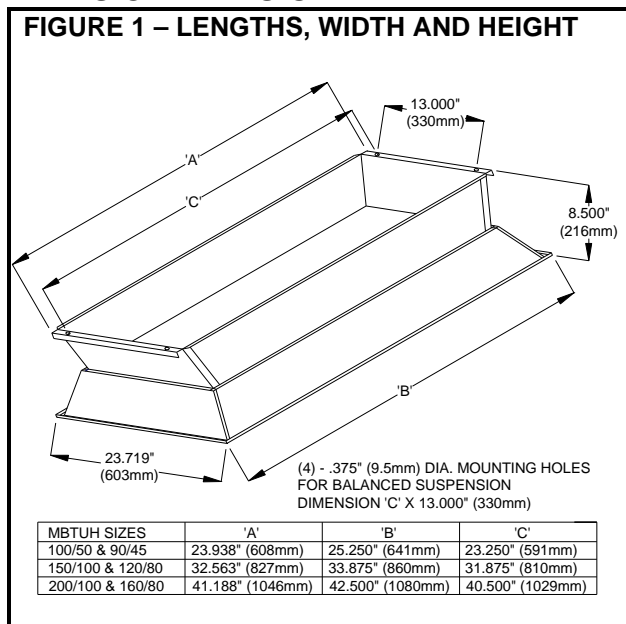

5. CLEARANCE TO COMBUSTIBLES

This heater model must be mounted with minimum clearances between the combustion surface and combustibles. Refer to Table 1, Clearance to Combustibles.

It should also be located with respect to building construction and equipment so as to provide sufficient clearance and accessibility for servicing and cleaning.

! WARNING !
 Single or multi-heater placement must be such that continuous operation of the heater or heaters will not cause combustible materials or materials in storage to attain a temperature in excess of 150°F (66°C).

! WARNING !
 Under no circumstances should this heater be installed in a combustible atmosphere or in a location where the heater controls can be subjected to ambient temperature in excess of 150°F (66°C). See hazard intensity levels, page 1.

It is recommended that more distance than the minimum clearance be maintained above the unit whether or not the construction is combustible. This will reduce and/or eliminate hot spots and possible staining of painted ceiling surfaces.

If the unit must be close to the roof or ceiling, interpose a non-combustible baffle (twice the size of the reflector) between the unit and the roof or ceiling. Allow at least 2" (5cm) between the roof or ceiling and the non-combustible baffle. Allow at least 12" (31cm) between the non-combustible baffle and the top of the heater.

TABLE 1. CLEARANCE TO COMBUSTIBLES

LP/PROPANE GAS MODELS (MBTUH)	90/45*	120/80	160/80
- (Kilowatts)	(26.4/13.2)	(35.1/23.4)	(46.9/23.4)
NATURAL GAS MODELS (MBTUH)	100/50*	120/80 & 150/100	200/100
- (Kilowatts)	(29.3/14.6)	(43.9/29.3)	(58.6/29.3)
CLEARANCE	Inches (cm)	Inches (cm)	Inches (cm)
SIDE OF HEATER	36 (91)	46 (117)	48 (122)
BACK OF HEATER	30 (76)	33 (84)	33 (84)
TOP OF HEATER:			
- Mounted 0-29°	62 (157)	64 (163)	68 (173)
- Mounted 30° only	50 (127)	58 (147)	68 (173)
- w/ Optional Heat Deflector 0-29°	38 (97)	N/A	N/A
- w/ Optional Heat Deflector 30° only	38 (97)	N/A	N/A
BELOW HEATER:			
- Standard Reflector	105 (267)	125 (318)	140 (356)
- w/ Optional Parabolic Reflector	135 (343)	165 (419)	180 (457)

*Note: See allowable mounting angles in Section 10, Suspending the Unit.

6. MOUNTING CONSIDERATIONS

Recommended mounting height and distance are given in Tables 2 and 3. Lower mounting height may be used if personnel are not required to stay directly under the heater. The clearance to combustibles distances must still be maintained.

TABLE 2. RECOMMENDED MOUNTING HEIGHT

MODEL MBTUH (kW)	With Standard Reflector HORIZONTAL ft (m)	With Standard Reflector At 30° ft (m)	With Optional Parabolic Reflector HORIZONTAL ft (m)	With Optional Parabolic Reflector at 30° ft (m)
90/45 (26.4/13.2)	16.0 – 18.5 (4.9 - 5.6)	14.5 – 17.0 (4.4 - 5.2)	19.5 – 22.5 (5.9 - 6.9)	17.5 – 20.5 (5.3 - 6.3)
100/50 (29.3/14.6)	17.0 – 19.5 (5.2 - 5.9)	15.0 – 17.5 (4.6 - 5.3)	20.5 – 23.5 (6.3 - 7.2)	18.5 – 21.5 (5.6 - 6.6)
120/80 (35.1/23.4)	17.5 – 21.0 (5.3 - 6.4)	15.5 – 18.5 (4.7 - 5.6)	21.5 – 25.0 (6.6 - 7.6)	20.0 – 23.0 (6.1 - 7.0)
150/100 (43.9/29.3)	18.5 – 22.5 (5.6 - 6.9)	16.5 – 20.0 (5.0 - 6.1)	24.0 – 27.5 (7.3 - 8.4)	21.5 – 24.5 (6.6 - 7.5)
160/80 (46.9/23.4)	19.0 – 23.0 (5.8 - 7.0)	17.0 – 20.5 (5.2 - 6.3)	25.0 – 28.5 (7.7 - 8.7)	22.5 – 25.5 (6.9 - 7.8)
200/100 (58.6/29.3)	20.5 – 25.0 (6.3 - 7.6)	18.5 – 22.5 (5.6 - 6.9)	27.0 – 31.0 (8.2 - 9.5)	24.5 – 28.0 (7.5 - 8.5)

TABLE 3. RECOMMENDED DISTANCE FROM A WALL FOR UNITS MOUNTED HORIZONTALLY

MODEL MBTUH (kW)	With Standard Reflector ft (m)	With Optional Parabolic Reflector ft (m)	Maximum Distance Between Heater Rows ft (m)
90/45 (26.4/13.2)	16 (4.9)	12 (3.7)	110 (33.5)
100/50 (29.3/14.6)	16 (4.9)	12 (3.7)	110 (33.5)
120/80 (35.1/23.4)	18 (5.5)	14 (4.3)	115 (35.1)
150/100 (43.9/29.3)	20 (6.1)	15 (4.6)	120 (36.6)
160/80 (46.9/23.4)	24 (7.3)	20 (6.1)	130 (39.6)
200/100 (58.6/29.3)	24 (7.3)	20 (6.1)	130 (39.6)

7. VENTILATION REQUIREMENTS

Every direct gas-fired heater installation requires sufficient fresh air to provide adequate combustion air and removal of products of combustion. Positive air replacement of 4 CFM per 1,000 BTUH ($0.38m^3/minute$ per kW) is required in the U.S. [**Canada** requires 3 CFM per 1,000 BTUH ($0.29m^3/minute$ per kW) for natural gas and 4 CFM per 1,000 BTUH ($0.38m^3/minute$ per kW) for LP/propane]. Many older buildings have air leakage to satisfy these requirements. Tightly constructed, well-insulated buildings require mechanically powered systems. This may be accomplished by the use of exhaust fans **AND** fresh air intake openings. BOTH exhaust fans and inlet air openings are required in tight buildings.

Mechanical exhaust fans are typically located at high points of the building. For flat roof areas, a series of small exhausters should be distributed over the roof areas and interlocked with various heating zones. Local codes may permit the use of humidistat control to remove water vapor and products of combustion. Humidistat settings will typically be in the 40-55% relative humidity range.

Fresh air intake openings should be located high on the building side walls at or above the level of the heaters. One square inch of net free inlet area per 1,000 BTUH ($22cm^2$ per kW) is required. Multiple inlets, well distributed, should be used and should direct air upward to prevent drafts at floor level. Inlets are typically limited to 1 to 2 square feet ($900 - 1800cm^2$) in size. **Total area required can be computed by dividing exhaust CFM by 500 feet per minute. (Total area required can be computed by dividing exhaust cubic meters per minute by 152 meters per minute.)**

8. GAS SUPPLY

- All piping must be installed according to local codes. Use new clean pipe. Inspect and clean out any chips or debris before installing the pipe and fittings.
- A flexible connection between the supply line and the heater may only be used if permitted by local code.
- Always use two wrenches when mating pipe connections to the heater. Excessive torque on the manifold may misalign gas orifices.
- Install a 1/8" N.P.T. plugged tap, accessible for test gauge connection, immediately upstream of the gas supply connection to the heater.
- A 6" (15 cm) drip leg trap at the inlet connection is recommended.
- If a pressure regulator is required, be sure that it is installed in the gas line with the arrow indicating gas flow pointing in the proper direction.
- Piping joint compound must be resistant to the action of liquefied petroleum gases.
- Do not subject gas pressure regulators, flex connectors, and gas cocks on the heater to test pressure over 14" W.C. (36cm WC) while checking for piping leaks.
- All piping joints must be tested for leaks with a leak detecting soap solution.

WARNING: All components of a gas supply system must be leak tested prior to placing equipment into service. NEVER test for leaks with an open flame. See hazard intensity levels, page 1.

- Purge all gas supply lines completely before attempting to ignite heater.

WARNING: Do not install any gas piping in heat zones.

9. ELECTRICAL SUPPLY AND THERMOSTATIC CONTROL

The electrical wiring to the appliance must be installed in accordance with the latest or current national and local codes that apply. This heating appliance has direct spark ignition.

! WARNING !

Appliances with direct spark ignition **MUST** be grounded.

ELECTRICAL REQUIREMENTS

- **Electrical supply: 24VAC - 60Hz - 1 Phase.**
- **3 wire service required.**
- **Maximum total heater current draw: 0.5Amps.**
- **Total heater power consumed: 12VA.**

Use 18/4 [18 AWG (0.8mm²)/4-conductor] solid class 2 thermostat cable having a minimum insulation temperature of 140°F (60°C) between thermostat and heater. Maximum length is 125 feet (38m).

Make connections as shown in Figure 2, Electrical Supply and Thermostat Wiring.

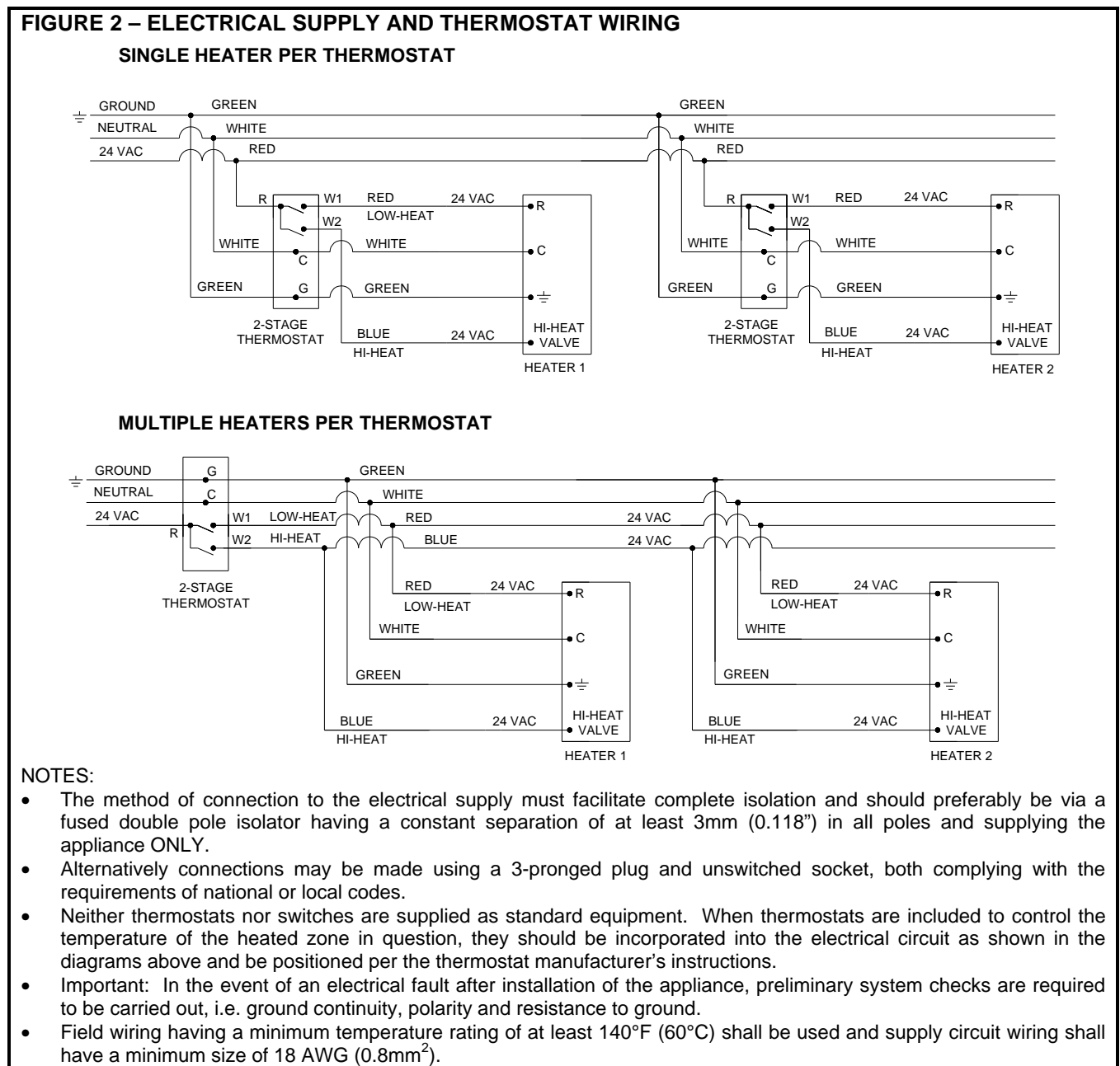

10. SUSPENDING THE UNIT

Before installing the unit, check the supporting structure to determine whether it has sufficient load carrying capacity to support the weight.

Mounting angle must be within the range allowed. Heaters may be angle mounted as listed in Table 4, Allowable Mounting Angle.

TABLE 4. ALLOWABLE MOUNTING ANGLE

MODEL MBTUH (kW)	NET WEIGHT lbs. (kg)	ALLOWABLE MOUNTING TOLERANCE
90/45 (26.4/13.2)	42 (19.0)	5° – 30°
100/50 (29.3/14.6)	42 (19.0)	5° – 30°
120/80 (35.1/23.4)	53 (22.6)	0° – 30°
150/100 (43.9/29.3)	53 (22.6)	0° – 30°
160/80 (46.9/23.4)	66 (29.9)	5° – 30°
200/100 (58.6/29.3)	66 (29.9)	0° – 30°

DO NOT ANGLE HEATERS MORE THAN 30°.

Be certain to check local codes for mounting requirements and permission to use flexible gas connectors. Local codes may require rigid mounting. It is recommended that either the piping or the mounting be flexible to prevent fatigue failure from vibration or thermal expansion.

For proper operation, the heater must be level, whether horizontal or angle mounted. When angle mounted, all models must be installed with the gas manifold located on the low end. See Figure 3, Typical Heater Mounting, Chain or Rigid.

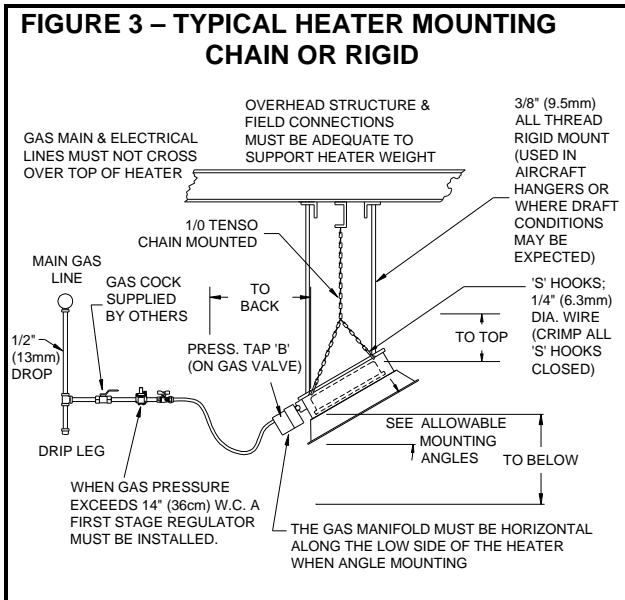

If a heater is located in an aircraft hangar or near overhead doors, it should be rigidly mounted to prevent swinging. The installer is responsible for suspension of the heater. **Under no circumstances should either the gas supply line or electrical supply line to the unit be used to provide assistance in suspension. Do not run any gas or electric service lines above or below the heater or near the path of the flue products.**

If permissible by local code, it is recommended that these heaters be suspended with chain and “S” hook mounting. See Figure 4, Chain Hanging Arrangement. Chain with 200# (91kg) working load (1/0 Tenso) is recommended. “S” hooks must be a minimum of 1/4” (6.3mm) diameter wire and must be closed after installation.

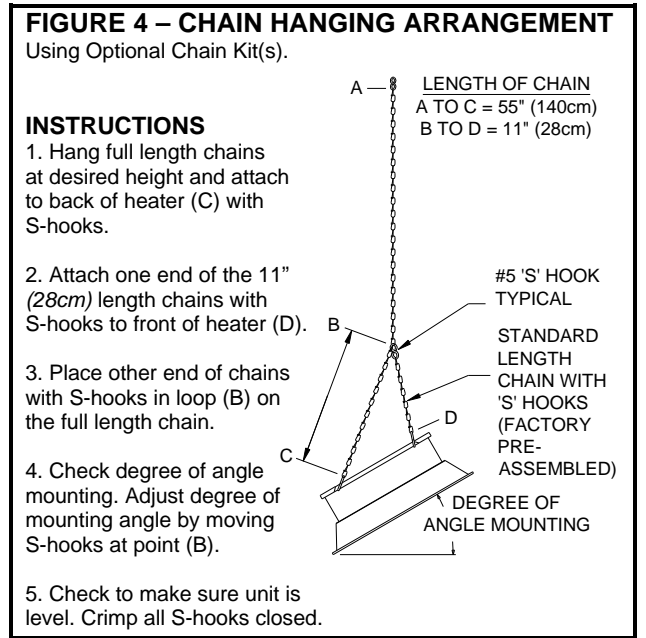

11. ASSEMBLY

The appliance should be raised and suspended from chains or drop rods or from brackets fixed to vertical surfaces which have been previously installed in accordance the Section 10, Suspending the Unit.

Connect the gas supply in accordance with Section 8, Gas Supply, of these installation instructions.

Connect the electrical supply wiring as specified in Section 9, Electrical Supply and Thermostatic Control. Connect incoming thermostat wires to the heater as follows:

- Red (lo-heat) - to the heater’s transformer terminal marked ‘R’.
- White (neutral) - to the heater’s transformer terminal marked ‘C’.
- Green (ground) - the heater’s green ground screw.
- Blue (hi-heat) - to the heater’s high heat valve.

12. IGNITION AND OPERATION

CONTROL SPECIFICATIONS:

Direct Spark Ignition (DSI) 24VAC – 60Hz – 1Phase.
See Figure 5, 24VAC DSI Wiring Schematic.

SEQUENCE OF OPERATION

1. Thermostat calls for heat; low-heat or hi-heat operation is determined by setpoint of thermostat. Refer to thermostat manufacturers' instructions.
2. Power is applied to the ignition detection control (IDC). 15 seconds after power is applied, a spark is developed at the electrodes and combination gas valve (CGV) opens.
3. Burner ignites; electrical current begins flowing from sensing electrode through flame to ground.
4. IDC senses current, turns OFF spark, gas continues to flow through the CGV. (Sparking may continue for full 15 seconds before stopping.)
5. On flame outage at sensing electrode, the IDC responds and begins sparking within 0.8 seconds. A 15-second trial-for-ignition period begins to re-light the burner. If flame is re-established, normal operation resumes. (Sparking may continue for full 15 seconds before stopping.) If the burner does not light after the first try, the inter-purge sequence is completed between trials to re-light the burner. If the burner fails

to light after third trial, the IDC will de-energize the CGV and go into lockout mode.

6. Should the burner fail to light or flame is not detected during first trial-for-ignition period, the CGV is de-energized and the IDC starts the 15-second inter-purge sequence before another ignition trial. After 15 seconds, the IDC begins 2 more ignition trials. If these trials fail, the control goes into lockout mode.
7. For lockout recovery, reset the thermostat below ambient temperature or disconnect electrical power supply for 5 seconds.

LIGHTING INSTRUCTIONS

1. Turn gas valve (CGV) knob to OFF position.
2. Turn electrical supply OFF.
3. Wait at least five (5) minutes.
4. Set thermostat above room temperature.
5. Turn gas valve (CGV) knob to ON position.
6. Turn electrical supply ON.
7. Set thermostat at desired temperature.
8. If heater does not light, repeat steps 1-7.

IMPORTANT: This control system cannot determine the presence of flame if it is not electrically grounded to the burner; it will lockout and shut off. Proper grounding and polarity are essential to its' operation.

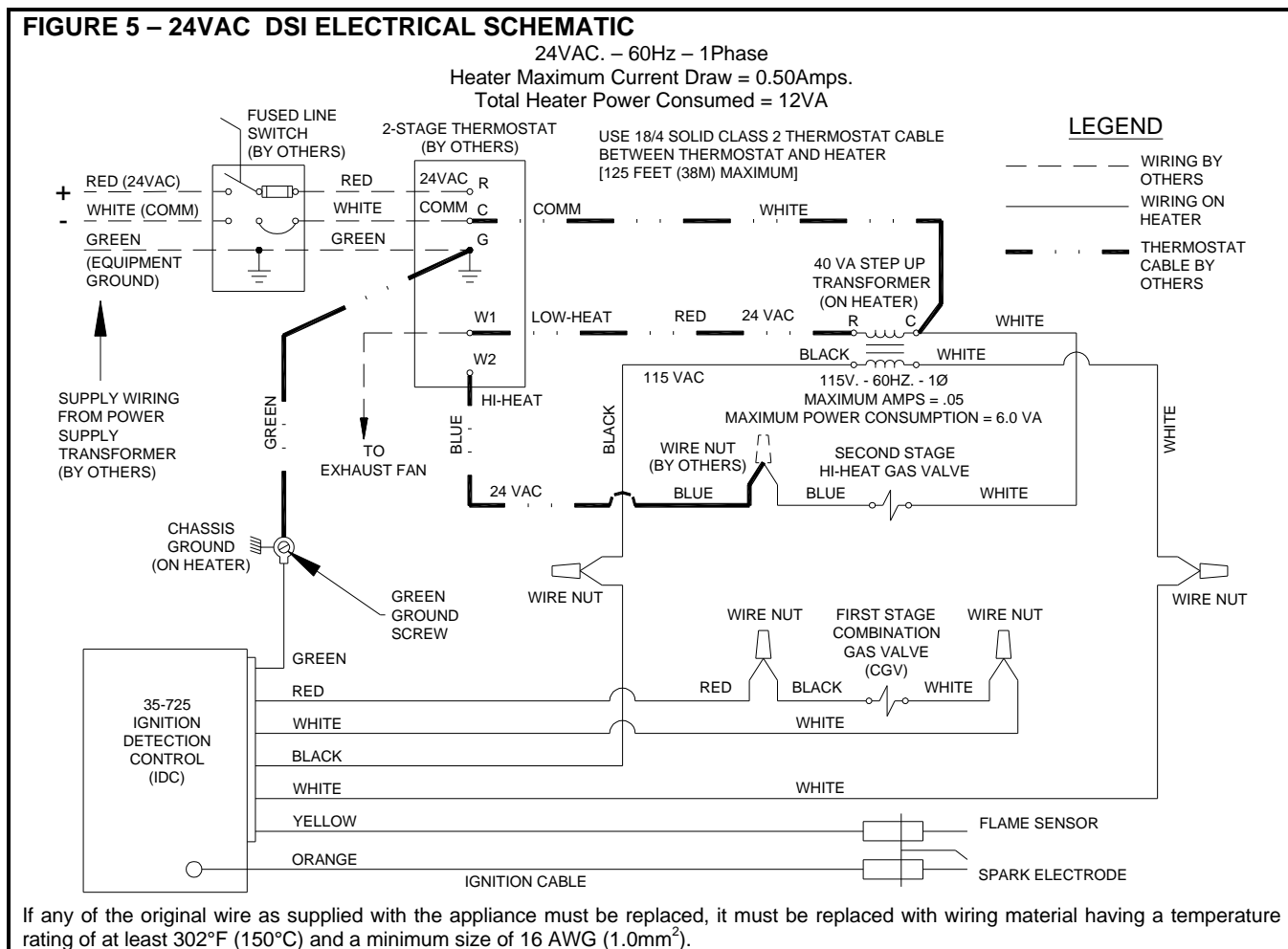

13. SHUT DOWN

To shut down the appliance for a period of time, switch off the electrical supply to the appliance.

To shut down the appliance for a period of time in excess of one week, switch off the electrical supply to the appliance and turn off the gas supply at the gas isolation valve.

14. GAS PRESSURE

The main supply line pressure must be limited to 14" W.C. (36cm WC). If the line pressure can go above 14" W.C. (1/2 p.s.i., 36cm WC) at any time, a separate lockup service regulator must be used. The minimum supply line pressure at the inlet to the heater regulator must, in no case, be lower than 7" W.C. (18cm WC) pressure for natural gas and 11" W.C. (28cm WC) pressure for LP gas.

Use a water or red oil manometer when checking gas pressures. **DO NOT USE A DIAL GAUGE.** All measurements must be made when this and **ALL** other gas burning equipment are operating at maximum capacity. Refer to Table 5, Gas Pressure Requirements.

TABLE 5. GAS PRESSURE REQUIREMENTS

TYPE OF GAS	LINE PRESSURE Water Column (W.C.)		MANIFOLD PRESSURE AT TAP IN GAS VALVE Water Column (W.C.)
	Minimum	Maximum	
Natural	7 in. (18cm)	14 in. (36cm)	6 in. (15cm)
Propane	11 in. (28cm)	14 in. (36cm)	10 in. (25cm)

Natural gas models are orificed for 1000 BTU/CU.FT (37MJ/m³) of gas. Propane gas models are orificed for 2500 BTU/CU.FT (93MJ/m³) of gas.

15. ACCESSORIES

The accessories listed are optional enhancements to the heaters that may be obtained from the factory.

CHAIN SET

Factory approved pre-cut chain pre-assembled with hooks or uncut chain with hooks.

FLEX CONNECTORS

Standard or weather resistant connectors for gas supply.

OPERATING CONTROLS

Thermostats (2-stage, programmable, night setback, line voltage, low voltage, weather resistant) for automatic operation.

PARABOLIC REFLECTOR

A parabolic reflector increases the infrared intensity pattern while decreasing the scope of heating coverage.

PROTECTIVE SCREEN

The screen protects the ceramic tile from damage caused by the entrance of foreign objects. Available for standard or parabolic reflectors.

HEAT DEFLECTOR

A heat deflector is available for sizes 30 – 100 MBTUH (8.8 – 29.3 kW) to permit less clearance above the heater. See Table 1, Clearance to Combustibles, in Section 5, Clearance to Combustibles.

16. MAINTENANCE AND SERVICE

See Figure 6, General Diagram of the Heater, for the location of major components of the heater.

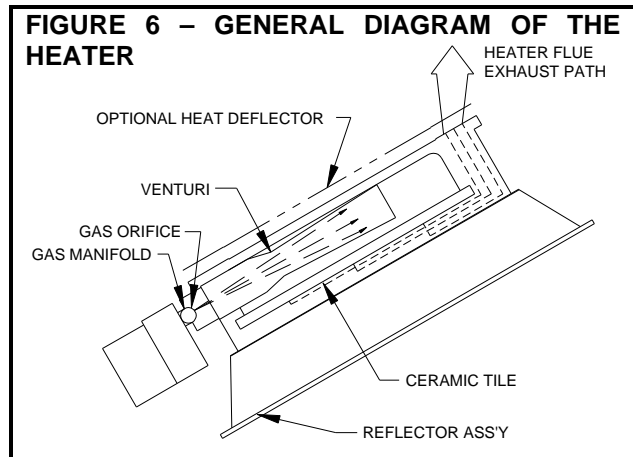

See Figure 7, Direct Spark Electrode Installed, for the electrode's orientation to and correct distance from the burner assembly's ceramic tile surface.

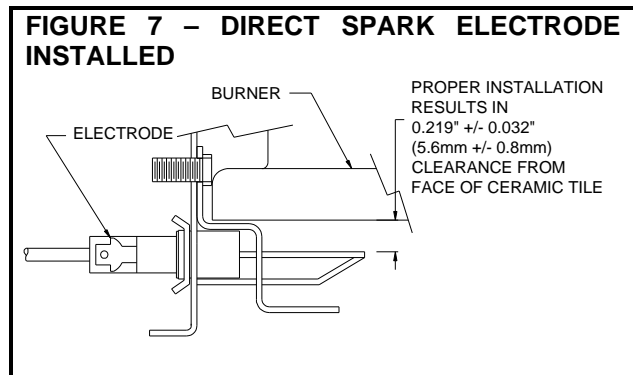

Annual maintenance should be performed as follows:

1. Disconnect all power sources related to the installation and close the gas supply valve at the heater.
2. With an air hose of 20 PSIG (138kpg) or less, blow off all accumulated dust and dirt.

CAUTION: Always wear protective goggles when cleaning heaters.

3. Pass the air hose over the ceramic tile and alternately into the venturi several times in succession.

17. GAS CONVERSION

It is feasible to convert the type of gas or BTUH (kW) rating of a heater after it is has been installed. Identify the model number and serial number of the heater. Consult factory for proper instructions and parts.

18. REPLACEMENT PARTS

The following is a list of replacement parts that may be required during the life of the heater. If it is necessary to replace parts other than those listed below, please contact the manufacturer at the address noted on the back cover of this manual.

PARTS

- HLK Second Stage Gas Valve (Sunwell)
- HLK Combination Gas Valve (White-Rogers)
- HLK Ignition Control (Fenwal)
- K Spark Electrode
- K-Head Ceramic Tile Burner Assembly each
- K2 Standard Reflector Assembly (Model HLK2)
- K3 Standard Reflector Assembly (Model HLK3)
- K4 Standard Reflector Assembly (Model HLK4)

BURNER HEAD REPLACEMENT

A burner head (K-Head Ceramic Tile Burner Assembly) is easily replaced as indicated in Figure 8, Burner Head Replacement.

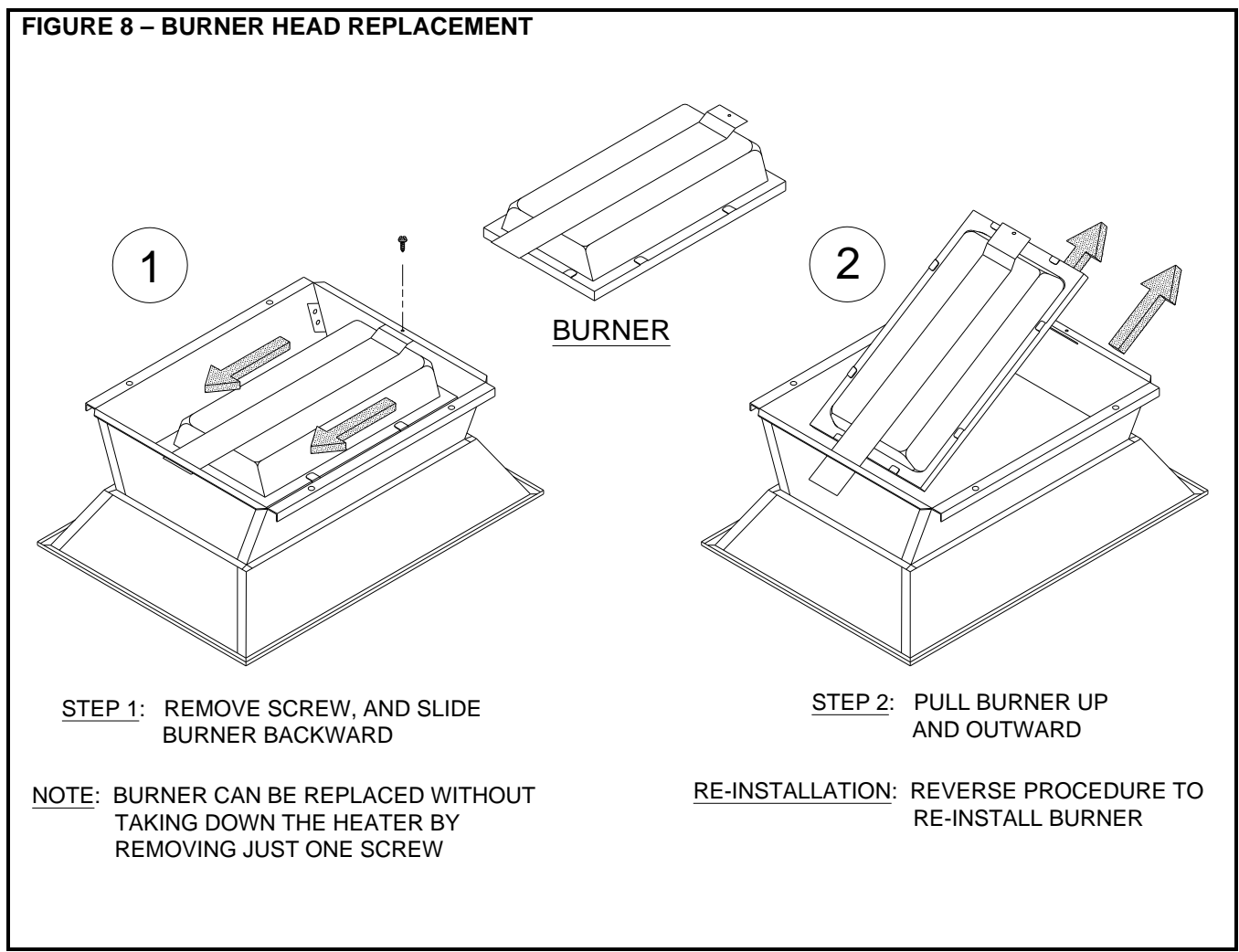

19. TROUBLESHOOTING

SYMPTOM	POSSIBLE CAUSE	CORRECTIVE ACTION
New Installation.	1. Heaters not isolated during high pressure leak testing	1. Replace combination gas valves on each heater
	2. All gas lines not completely bled of air	2. Disconnect flex hose at each heater until gas is present. Connect flex hose and leak test
	3. Gas supply regulator reversed	3. Remove and install properly
Gas Odor	1. Gas pipe joints loose	1. Check joints with soap solution, tighten as needed
Electrical circuit closed but heater not working. (For specific control systems see Ignition and Operation section)	1. Gas supply lacking caused control system lockout	1. Verify all gas supply valves are open. Purge air from gas supply line. Turn thermostat off – wait 5 minutes, then reset thermostat
	2. Line fuse blown or tripped circuit breaker	2. Replace line fuse or reset breaker
	3. Electrical power short	3. Trace and correct short
	4. Wiring disconnected	4. Repair, see wiring diagram in Ignition section
	5. Exhaust fan interlock (if used) is defective	5. Replace interlock
Direct spark fails to ignite main burner(s)	1. Electrode wire loose	1. Reconnect wire
	2. Electrode wire broken or frayed	2. Replace electrode
	3. Electrode ceramic cracked	3. Replace electrode
	4. Electrode improperly located	4. Relocate to correct position
	5. Gas supply valves not opened	5. Open all manual gas supply valves
	6. Combination gas valve not in the ON position	6. Turn combination gas valve to ON position
	7. Gas valve fails to open when power applied	7. Replace gas valve
	8. Supply/manifold gas pressure too low	8. See rating plate on heater and adjust pressure(s)
	9. Gas supply regulator sticking	9. Replace gas supply regulator
	10. Ignition detection control defective	10. Replace ignition detection control
Unit cycles on and off	1. Drafty condition	1. Shield heater from drafts
	2. Flame sensor wire is loose or damaged	2. Replace wire harness to ignition detection control
	3. Ignition detection control defective	3. Replace ignition detection control
Heater will not turn off	1. Thermostat defective	1. Break electrical circuit and replace thermostat.
Transition from low-heat to hi-heat does not happen	1. Ambient temperature is still in low-heat zone of thermostat	1. Check thermostat manufacturers' instructions
	2. Thermostat defective	2. Replace thermostat
	3. Hi-heat valve not opening	3. Replace hi-heat valve
Transition from hi-heat to low-heat does not happen	1. Ambient temperature has not reached low-heat zone of thermostat	1. Allow time for ambient temperature to reach low-heat zone of thermostat. Check thermostat manufacturers' instructions
	2. Thermostat defective	2. Replace thermostat
	3. Hi-heat valve not closing	3. Replace hi-heat valve
Controls overheating	1. Heater mounted incorrectly	1. See Mounting and Suspending sections
Burning of gas inside burner (flash-back)	1. Heater mounted incorrectly	1. See Mounting and Suspending sections
	2. Gas leaking from: manifold, control assembly, or pilot joints causing gas ignition at orifice	2. Check joints with soap solution, tighten as needed
	3. Ceramic tile(s) cracked or separating	3. Replace burner
	4. Drafts excessive	4. Shield from drafts or relocate heater
Carbon formation on ceramic surface or burner	1. Gas supplied is wrong type	1. Check rating plate for type of gas required
	2. Venturi obstructed (by spider web)	2. Clean with a bottle brush
	3. Supply/manifold gas pressure too low	3. See rating plate on heater and adjust pressure(s)
	4. Orifice(s) misaligned	4. Consult sales agent or factory
Dark spots on ceramic surface	1. Foreign matter behind the ceramic surface	1. See Maintenance section
	2. Foreign matter inside burner assembly	2. Replace burner assembly
Low ceramic surface temperature	1. Venturi obstructed (by spider web)	1. Clean with a bottle brush
	2. Foreign matter in venturi	2. See Maintenance section
	3. Orifice partially blocked	3. See Maintenance section
	4. Supply gas pressure low	4. Adjust supply regulator to 7" WC (18cm WC) for natural gas, or 11" WC (28cm WC) for propane
	5. Manifold gas pressure low	5. Adjust heater regulator to 6" WC (15cm WC) for natural gas, or 10" WC (25cm WC) for propane
	6. Manifold misaligned from excessive torque applied on pipe at installation	6. Replace manifold
	7. Flue gases not adequately ventilated	7. See Ventilation Requirements section
	8. Gas supply piping too small	8. Increase supply pressure or replace piping

THIS PAGE INTENTIONALLY LEFT BLANK

FOR SERVICE OR REPAIR, FOLLOW THESE STEPS IN ORDER:

FIRST: Contact the Installer

Name _____

Address _____

Phone _____

SECOND: Contact the Nearest Distributor

Model No.: _____

Unit Serial No.: _____

Date of Installation: _____



Easy Radiant "Works"

12288 Side Road 22, Wainfleet, Ontario, Canada L0S1V0
Phone 905 899 3473 Fax 905 899 2262
www.erwcan.com email erw@vaxxine.com